

CHAFLANADORA / BEVELLING MACHINE / CHANFREINEUSE

MODELO

CHP-21G

PATENTADO

GRADUABLE
ADJUSTABLE
AJUSTABLE
20 ÷ 45°



CHP-21G

CHP-21G INV

CHP-21G REV



TRANSPORTABLE





MODELO
CHP-21G
CHP-21G INV
CHP-21G REV

CHP-21G

Esta máquina realiza 1,7 m./minuto de chaflán para alojar cordones de soldadura con una profundidad de 20 mm. en placas hasta de 50 mm. de espesor y 40 Kg/mm² de resistencia.

This machine performs 1,7 m/minute bevel to receive welding seams with 20 mm. depth in plates up to 50 mm. thickness and 40 Kg/mm² strength.

Cette machine exécute 1,7 m/minute de chanfrein pour des soudures continues avec un profondeur de 20 mm. sur des planches jusqu'à 50 mm. d'épaisseur et 40 Kg/mm² de résistance.

CARACTERISTICAS

Potencia del motor..... 4 C.V.
 Voltaje..... 220/380 V. 50 Hz.
 250/440 V. 60 Hz.
 Caja eléctrica: con disparo a mínima tensión
 Seta emergencia y
 protección magnetotérmica
 Interruptor inversor de marchas
 Longitud de chaflanado
 por minuto..... 1,7 m.
 Profundidad máx. de chaflán
 en materiales de 40 Kg/mm² 20 mm.
 Profundidad máx. de chaflán
 en materiales de 50 Kg/mm² 16 mm.
 Angulo de chaflanado..... 20 ÷ 45°
 Espesor de chapa..... 9 a 50 mm.
 Chaflanado de tubos: Ø min. interior .. 150 mm.
 Peso neto de la máquina..... 370 Kg.

CHARACTERISTICS

Motor power..... 4 C.V.
 Voltage..... 220/380 V. 50 Hz.
 250/440 V. 60 Hz.
 Electric box : with minimum voltage trip
 switch, emergency
 Mushroom-type stop button and
 magneto-thermal protection
 Running inverter-switch
 Beveling length
 per minute.....1,7 m.
 Max. bevel depth with
 40 Kg/mm² materials.....20 mm.
 Max. bevel depth with
 50 Kg/mm² materials..... 16 mm.
 Beveling angle..... 20 ÷ 45°
 Plate thickness..... 9 a 50 mm.
 Beveling tubes: min.inner Ø 150 mm.
 Net weight of the machine..... 370 Kg.

CARACTERISTIQUES

Puissance du moteur..... 4 C.V.
 Voltage..... 220/380 V. 50 Hz.
 250/440 V. 60 Hz.
 Boite électrique: avec déclenchement
 à tension minimum
 Bouton d'arrêt d'urgence et protection
 magnétothermique
 Interrupteur inverseur de marches
 Longueur de chanfreinage
 par minute..... 1,7 m.
 Profondeur máx. de chanfrein
 avec des matériaux de 40 Kg/mm² 20 mm.
 Profondeur máx. de chanfrein
 avec des matériaux de 50 Kg/mm² 16 mm.
 Angle de chanfreinage..... 20 ÷ 45°
 Epaisseur de la tole..... 9 a 50 mm.
 Chanfreinage sur des tubes:Ø min. intérieur.. 150 mm.
 Poids net de la machine..... 370 Kg.

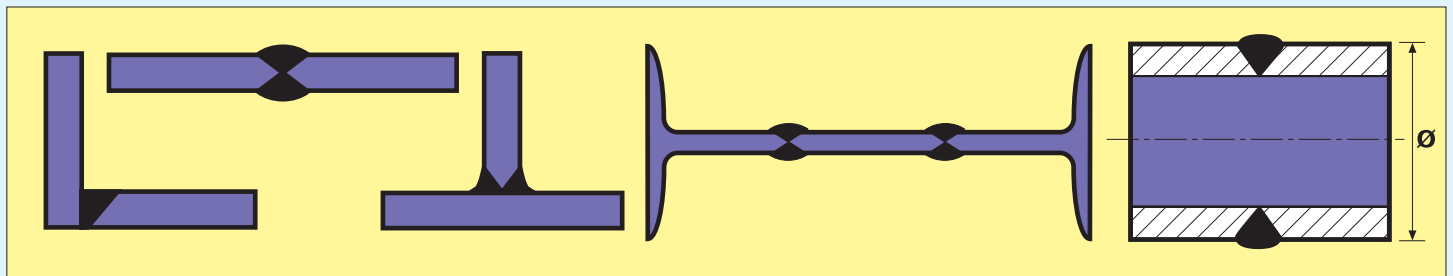

Chaflanado de piezas pequeñas multiformes.
 Beveling multi-form little parts.
 Chanfreinage de petites pieces multiformes.

Chaflanado de tubos.
 Beveling tubes.
 Chanfreinage sur des tubes.

Chaflanado en chapa larga avanzado sobre carro. CHP-21G REV girando.
 Beveling large pieces moving forward on the trolley. CHP-21G REV turning around.
 Chanfreinage de grandes pièces avançant sur le chariot. CHP-21G REV tournant autour.

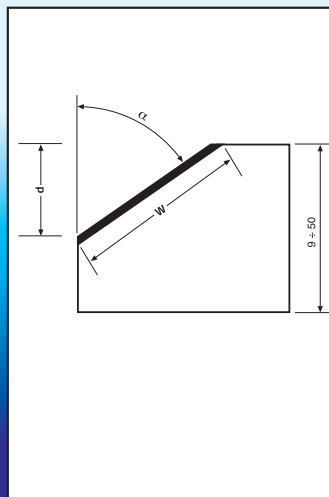
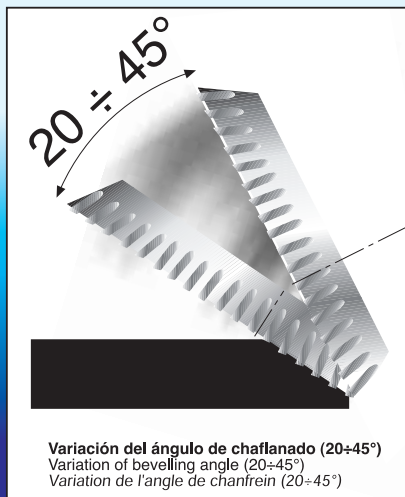

ACEROS AL CARBONO / CARBON STEELS / ACIERS						
α	R = 40 Kg/mm ²		R = 50 Kg/mm ²		R = 60 Kg/mm ²	
	w	d	w	d	w	d
20°	20	19	16	15	13	12
25°	20	18	16	14,5	13	12
30°	20	17,5	16	14	13	11
35°	20	16,5	16	13	13	10,5
37,5°	20	16	16	12,5	13	10
45°	20	14	16	11,5	13	9
X°	20	W*cosα	16	W*cosα	13	W*cosα

ALEADOS-INOXIDABLES / STAINLESS-ALLOYED STEELS / INOX - ALLIE						
α	R = 50 Kg/mm ²		R = 60 Kg/mm ²		R = 70 Kg/mm ²	
	w	d	w	d	w	d
20°	9,5	9	8	7,5	7	6,5
25°	9,5	8,5	8	7,5	7	6,5
30°	9,5	8	8	7	7	6
35°	9,5	8	8	6,5	7	6
37,5°	9,5	7,5	8	6,5	7	5,5
45°	9,5	6,5	8	5,5	7	5
X°	9,5	W*cosα	8	W*cosα	7	W*cosα